

TOTAL PERFORMANCE
VAN'S AIRCRAFT

14401 Keil Road NE, Aurora, Oregon, USA 97002

PHONE 503-678-6545 • FAX 503-678-6560 • www.vansaircraft.com • info@vansaircraft.com

Service Letters and Bulletins: www.vansaircraft.com/public/service.htm

SERVICE BULLETIN 14-01-31

Date Released: January 31, 2014

Date Effective: January 31, 2014

Subject: Cracking near the bend in horizontal stabilizer front spar.

Affected Models: All RV-6/6A,7/7A,8/8A Flying or under construction

Synopsis:

Cracks in the forward spar of the horizontal stabilizer have been found emanating from the stress relief notch at the inboard end of the spar flanges. See Figure 1 and remaining figures in this bulletin.

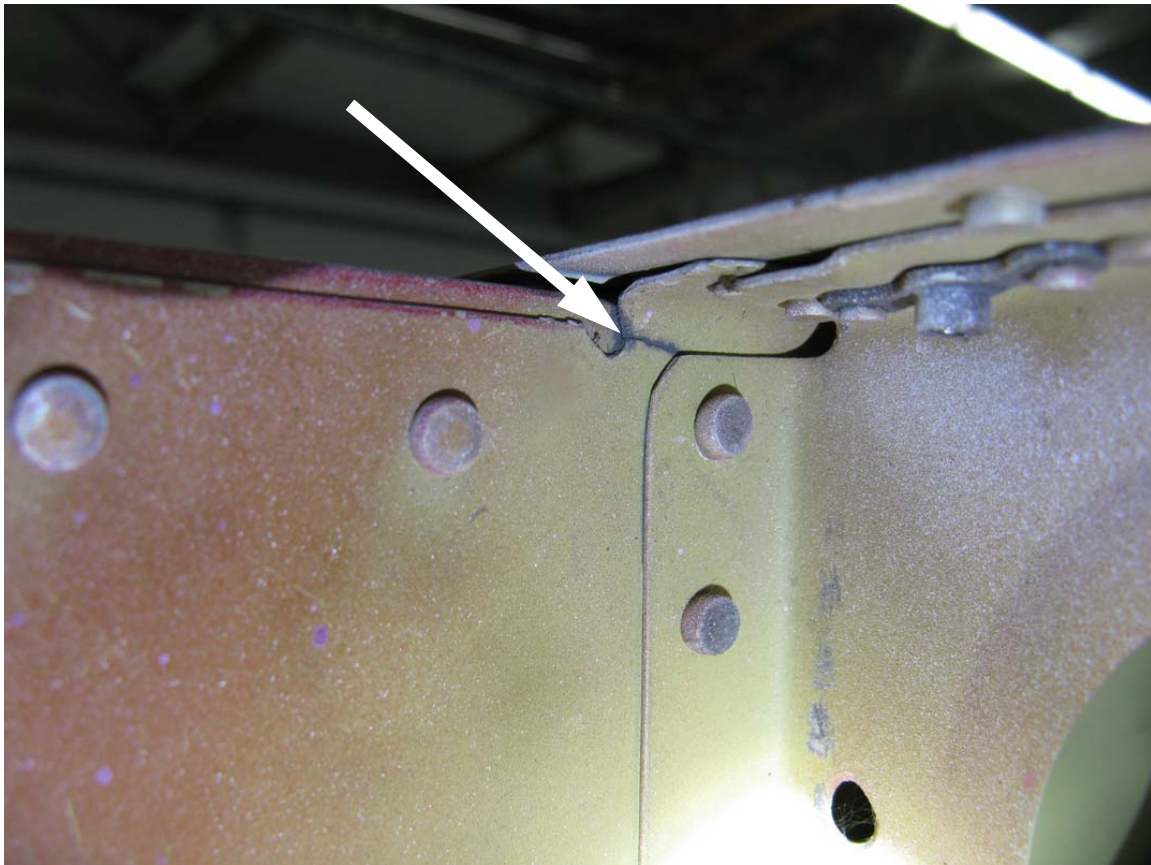

FIGURE 1: Typical crack in horizontal front spar web emanating from relief notch.

TOTAL PERFORMANCE VAN'S AIRCRAFT

14401 Keil Road NE, Aurora, Oregon, USA 97002

PHONE 503-678-6545 • FAX 503-678-6560 • www.vansaircraft.com • info@vansaircraft.com

Service Letters and Bulletins: www.vansaircraft.com/public/service.htm

Required Action:

Inspect for cracks as described. If cracks are present, stop drill cracks and install HS-00001 Doubler (RV-6,7) or HS-00003 Doubler (RV-8) and HS-00002 Rib Flange Angle (RV-6,7) or HS-00004 Rib Flange Angle (RV-8) to both sides of the aircraft before further flight.

Time of Compliance:

Inspect before further flight and at each annual condition inspection until such time that this service bulletin has been complied with in its entirety.

NOTES:

- 1) **RV-7 part numbers will be used in this bulletin unless otherwise specified. Part numbers specific to your model of aircraft will be similar except the first number of the part number will be different. For example HS-702 (RV-7) would be HS-602 (RV-6). Use the plans set that came with your kit to determine part numbers specific to your aircraft.**
- 2) **For repairs to an RV-8 the HS-00003 Spar Doubler will be used in place of the HS-00001 Spar Doubler.**
- 3) **Special tools required:**
 - 90° Angle Drill with 1 1/2" long #30 and #40 drills**
 - Offset AN470-4 Rivet Set**
 - 12" long #30 Drill**
- 4) **Proper procedures must be used in removing rivets. Improper procedures that cause enlarged rivet holes could be more detrimental than cracks in the spar web. When using an angle drill for rivet removal, maintaining proper drill alignment can be challenging. Using the recommended drill bit lengths, along with a cleco inserted in an adjacent hole to use as an alignment reference will help significantly. The latest version of Section 5 available for download from the service information page for your aircraft on the Van's Aircraft web site includes further information on rivet removal.**

TOTAL PERFORMANCE VAN'S AIRCRAFT

14401 Keil Road NE, Aurora, Oregon, USA 97002

PHONE 503-678-6545 • FAX 503-678-6560 • www.vansaircraft.com • info@vansaircraft.com

Service Letters and Bulletins: www.vansaircraft.com/public/service.htm

Method of Compliance:

Inspection: Remove the Empennage fairing. Carefully inspect for cracks emanating from the stress relief notch at the inboard end of the forward horizontal stabilizer spar flanges. (see Figure 1 and figure 3). Clean the area and remove any paint, overspray or primer that could hide a crack. Cracks may be very small and hard to detect.

If no cracks are detected, no immediate action is necessary. Repeat this inspection at each subsequent annual condition inspection until such time that this service bulletin has been complied with in its entirety.

If cracks are detected, or if the doublers are to be installed as preventative maintenance, comply with the following steps: (Parts available from Van's. See last page)

Step 1: Remove the horizontal stabilizer from the aircraft. This will require removing the empennage fairing elevators, vertical stab and rudder as well as disconnecting the rudder cables, elevator pushrod and trim system. Reference the instructions that came with your aircraft.

Step 2: Remove the two most inboard rivets common between the HS-601PP Skins and the top and bottom flanges of the HS-702 Front Spar for both sides of the assembly as shown in Figure 2. See Section 5.4.

Step 3: Remove the rivets attaching the HS-404 Nose Ribs and HS-405 Main Ribs to the skins. See Figure 2.

Step 4: Remove the rivets holding the HS-404 Nose Ribs and HS-405 Main Ribs to the front and rear spars. Mark left or right on the inside face of the main ribs and nose ribs. Remove the ribs and set aside for later reuse.

Step 5: Inspect the HS-405 Main Ribs removed in Step 4 for cracks. If cracks are present that will not be removed when trimming off the forward flange of the main ribs (See Step 10), replace the ribs.

Step 6: Remove the rivets holding the HS-710 Reinf. Angle to the front spar. Remove the angle and double check that the corners of the fwd facing flange have been relieved as shown in the Figure 2 detail view.

Refer to the following for guidance:

Aircraft Model:	Part #:	Drawing:	Revision:
RV-6/6A or early RV-7/7A	HS-610	DWG 3PP	R3
RV-7/7A	<i>Match-Hole Emp - Not Applicable</i>		
RV-8/8A	HS-810	DWG 3PP	R3
RV-8/8A	<i>Match-Hole Emp - Not Applicable</i>		

Set aside the angle for later reuse.

TOTAL PERFORMANCE VAN'S AIRCRAFT

14401 Keil Road NE, Aurora, Oregon, USA 97002

PHONE 503-678-6545 • FAX 503-678-6560 • www.vansaircraft.com • info@vansaircraft.com

Service Letters and Bulletins: www.vansaircraft.com/public/service.htm

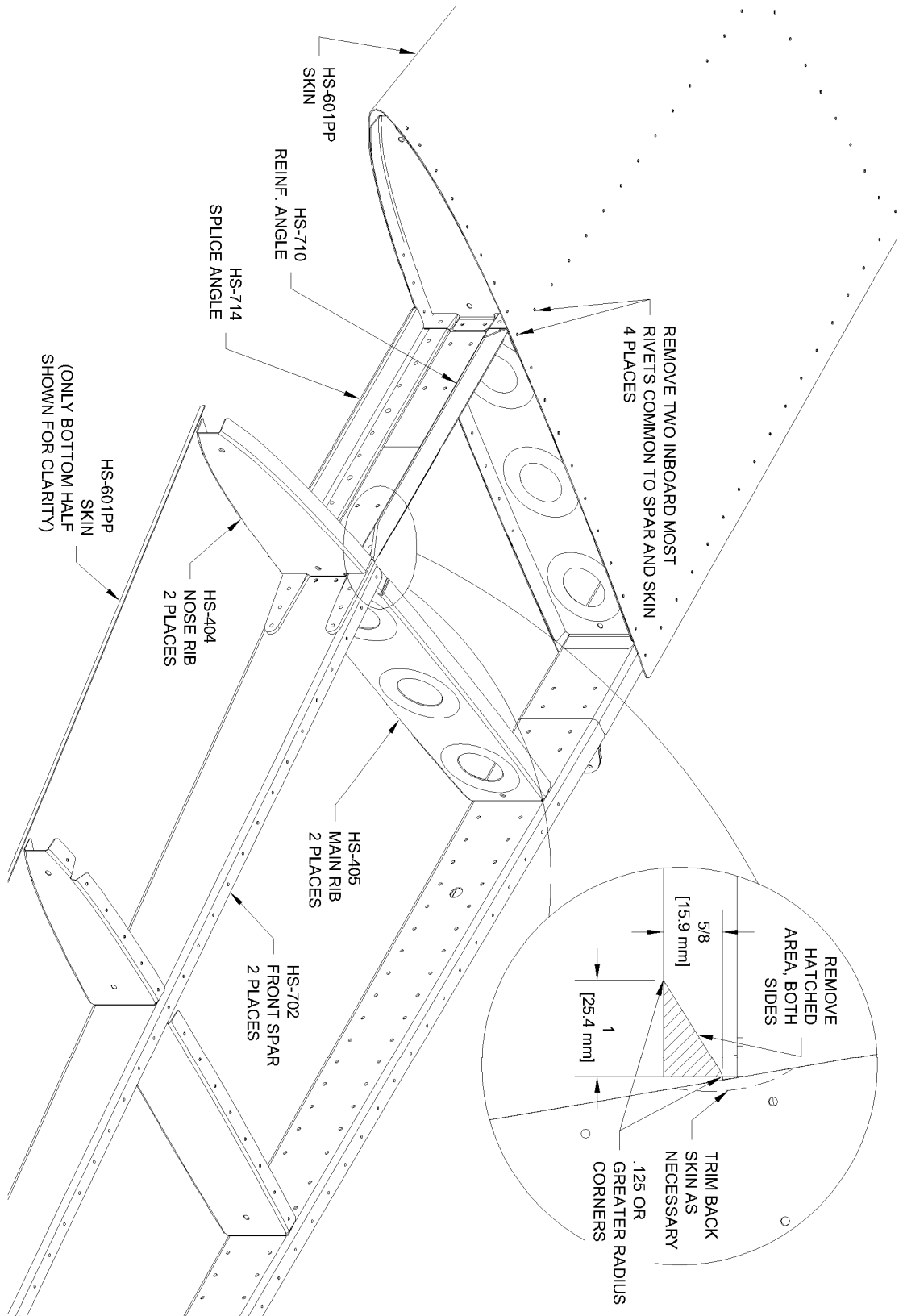

FIGURE 2: HORIZONTAL STAB ASSEMBLY

TOTAL PERFORMANCE
VAN'S AIRCRAFT

14401 Keil Road NE, Aurora, Oregon, USA 97002

PHONE 503-678-6545 • FAX 503-678-6560 • www.vansaircraft.com • info@vansaircraft.com

Service Letters and Bulletins: www.vansaircraft.com/public/service.htm

Step 7: Remove the rivets holding the HS-714 Splice Angle to the front spar. Remove the angle and set aside for later reuse.

Step 8: Inspect the corners at the inboard end of the top and bottom fwd spar flanges on the left and right spar halves for the presence of relief notches as depicted in Figure 3.

If notches are not present, use a round file to add relief notches (first refer to the following step... adding a missing notch may be done in conjunction with removing a crack). This will require trimming the skin slightly as shown in Figure 2 to gain access for the file.

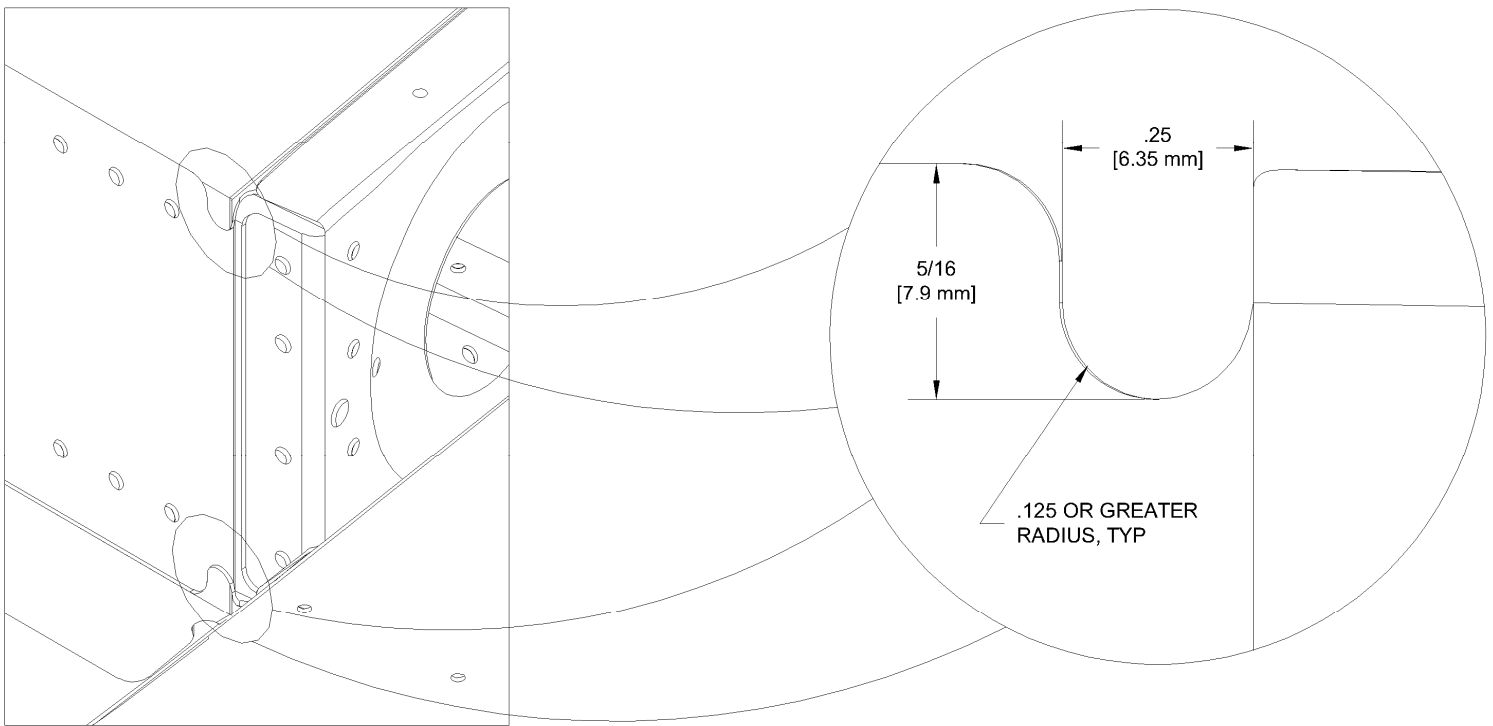

FIGURE 3: RELIEF NOTCHES

TOTAL PERFORMANCE
VAN'S AIRCRAFT

14401 Keil Road NE, Aurora, Oregon, USA 97002

PHONE 503-678-6545 • FAX 503-678-6560 • www.vansaircraft.com • info@vansaircraft.com

Service Letters and Bulletins: www.vansaircraft.com/public/service.htm

Step 9: Carefully inspect any detected cracks for length and termination point.

If cracks are 1/8 inch or shorter use a file to increase the size of the stress relief notch enough to remove the crack. File past the visible end of the crack 1/16 inch. Blend the shape of the filed away area by increasing the overall size of the relief notch.

If cracks are longer than 1/8 inch stop drill the crack using a #40 drill bit and then deburr.

Ignore cracks that have already propagated to a HS-405 Main Rib forward flange attach rivet hole. The rivet hole will act as a relief hole.

For any crack that has propagated outboard of the footprint of the HS-405 Main Rib contact Van's Aircraft for further assistance.

Step 10: Trim the upper and lower inboard flanges of the Front Spar per the dimensions shown in Figure 4. (Insert a piece of stainless steel sheet scrap between the skin and the flange of the front spar to protect the skin from damage while trimming.) Radius and deburr as well as possible, the cut edge of the spar flange. We have obtained good results using a Dremel™ style tool with a thin abrasive cutting disk, to make the cut.

TOTAL PERFORMANCE VAN'S AIRCRAFT

14401 Keil Road NE, Aurora, Oregon, USA 97002

PHONE 503-678-6545 • FAX 503-678-6560 • www.vansaircraft.com • info@vansaircraft.com

Service Letters and Bulletins: www.vansaircraft.com/public/service.htm

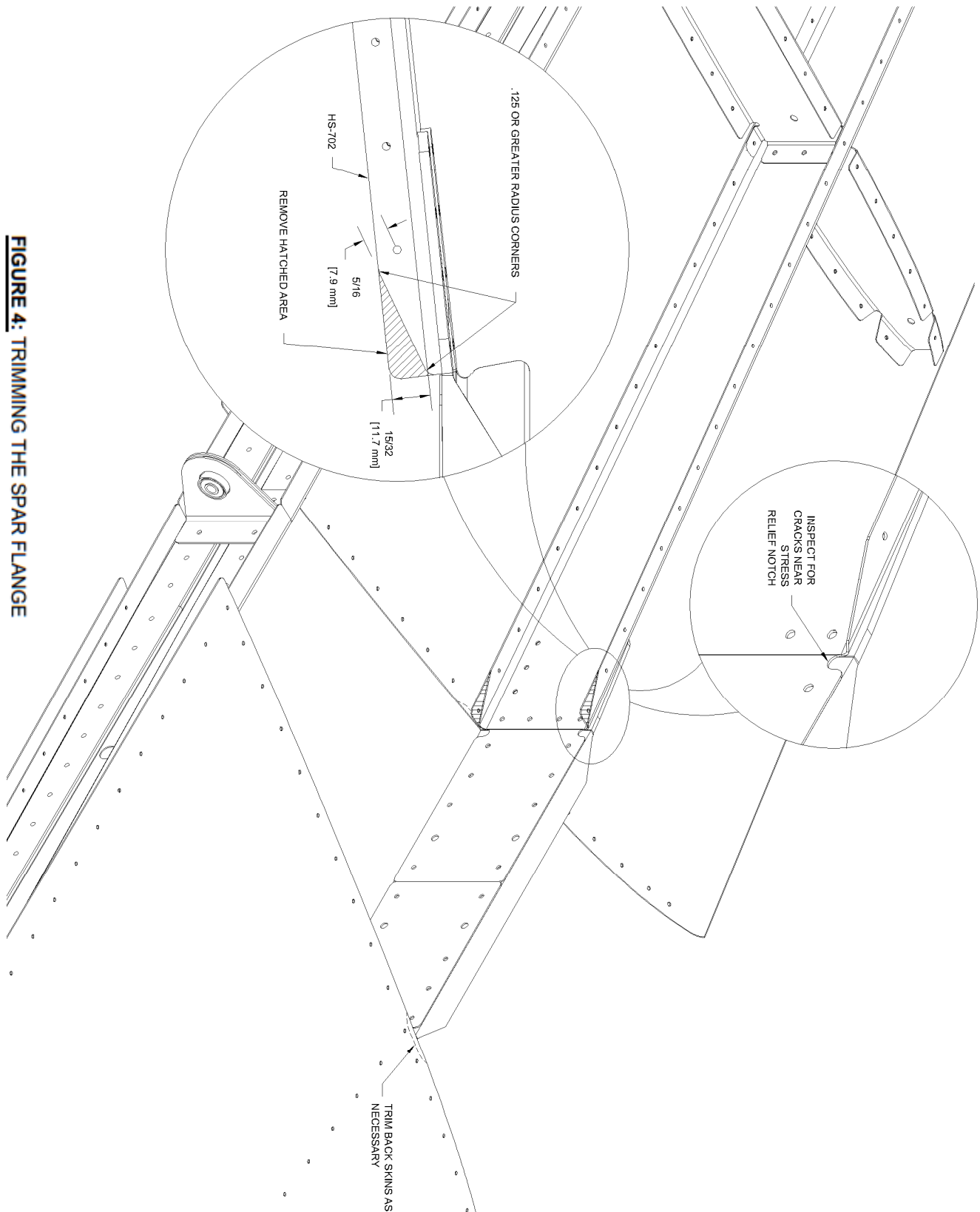

FIGURE 4: TRIMMING THE SPAR FLANGE

TOTAL PERFORMANCE VAN'S AIRCRAFT

14401 Keil Road NE, Aurora, Oregon, USA 97002

PHONE 503-678-6545 • FAX 503-678-6560 • www.vansaircraft.com • info@vansaircraft.com

Service Letters and Bulletins: www.vansaircraft.com/public/service.htm

Step 11: Radius the outboard forward “cut” edge as shown in Figure 5.

Step 12: Mark then drill #40 the four locations shown in Figure 5 for each HS-405 Main Rib.

Step 13: Final Drill #27 the fwd most hole in the top and bottom flange of the main ribs as shown in Figure 5.

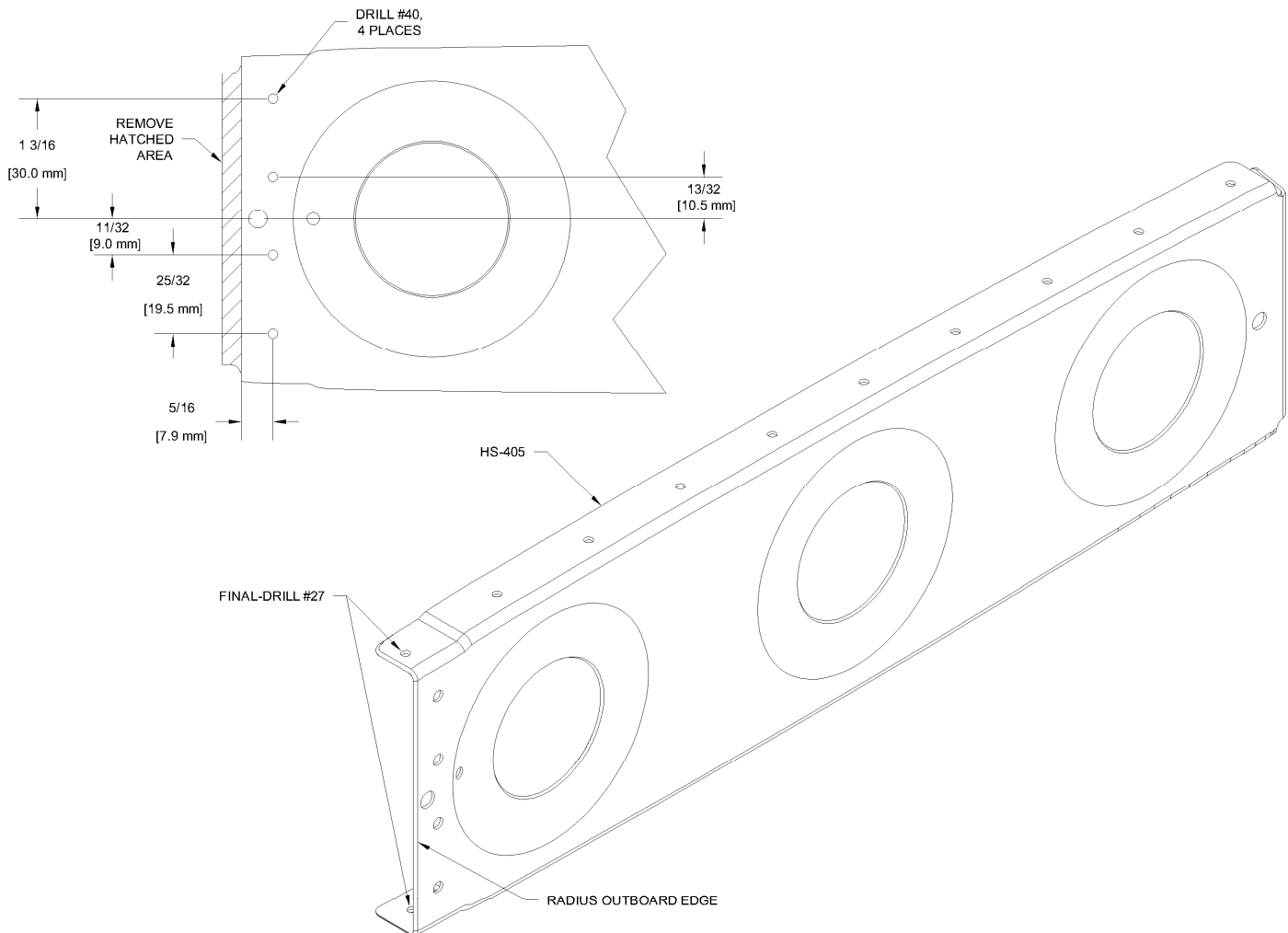

FIGURE 5: MAIN RIB PREP

TOTAL PERFORMANCE VAN'S AIRCRAFT

14401 Keil Road NE, Aurora, Oregon, USA 97002

PHONE 503-678-6545 • FAX 503-678-6560 • www.vansaircraft.com • info@vansaircraft.com

Service Letters and Bulletins: www.vansaircraft.com/public/service.htm

Step 14: Separate the HS-00001 (RV-6,7) or HS-00003 (RV-8) Spar Doublers into left and right parts as shown in Figure 6. Deburr the edges of the doublers.

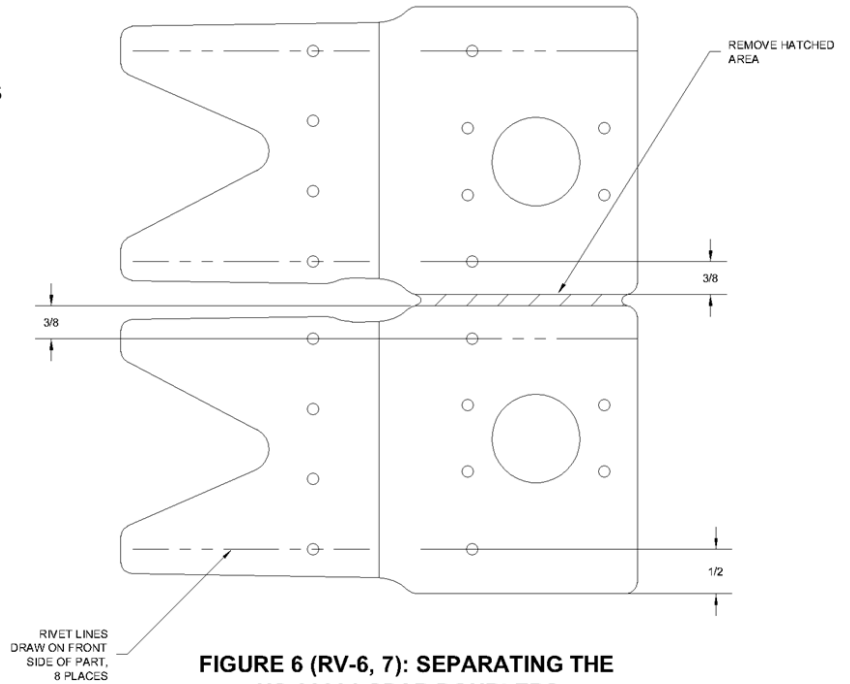

**FIGURE 6 (RV-6, 7): SEPARATING THE
HS-00001 SPAR DOUBLERS
(FRONT VIEW)**

Step 15: Draw rivet lines on the front side of the doublers as shown in Figure 6. When viewed from the front, the flanges will appear to be bent down.

NOTE: the rivet lines are centered on the pre-punched holes.

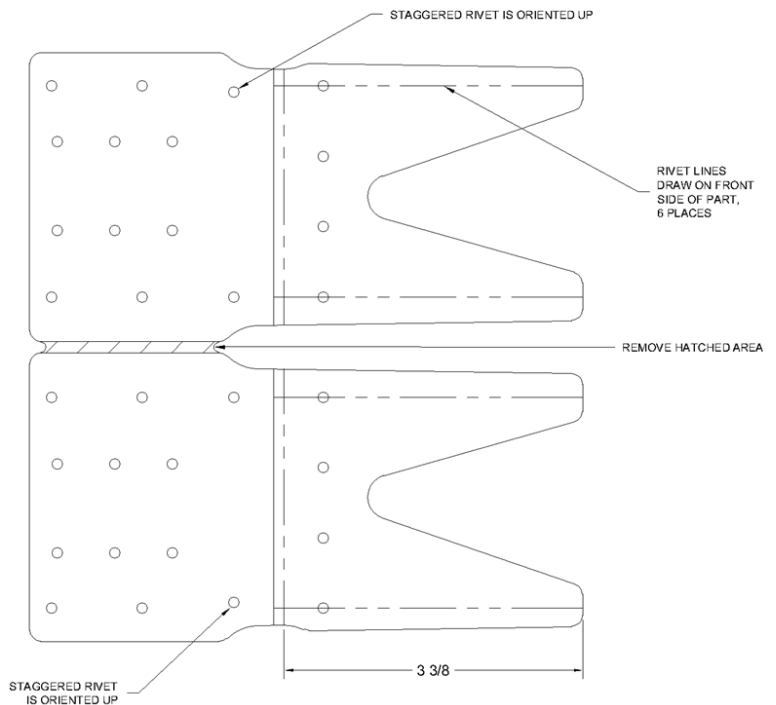

**FIGURE 6 (RV-8): SEPARATING THE
HS-00003 SPAR DOUBLERS
(FRONT VIEW)**

TOTAL PERFORMANCE
VAN'S AIRCRAFT

14401 Keil Road NE, Aurora, Oregon, USA 97002

PHONE 503-678-6545 • FAX 503-678-6560 • www.vansaircraft.com • info@vansaircraft.com

Service Letters and Bulletins: www.vansaircraft.com/public/service.htm

Step 16: Radius the edge noted in Figure 7 to fit against the upper radius of the front spar.

Step 17: Fit the doublers against the aft side of the front spar spanwise by lining up the bend in the doubler with the bend in the front spar. Align the part vertically, positioning the drawn rivet lines equally in relation to the existing holes in the front spar web. Clamp the doublers to the spar.

Existing holes in the doublers should NOT match up to existing holes in the part but rather be in-between. Measure the width of the attach plate for the front spar of the vertical stabilizer. Use this dimension to double check that the doublers are positioned correctly. It is permissible to trim off up to 1/16 from the inboard edge of the doublers if there is interference. If more trimming is required double check that the doublers are positioned correctly as matching the bend in the doubler and spar may not be obvious.

Match-Drill #30 then cleco the six (for RV-6,7) or eight (for RV-8) center holes in each doubler indicated in Figure 7 into the front spars then remove the clamps.

Match-Drill #30 the doublers using the two spar web hole locations shown in Fig 7.

TOTAL PERFORMANCE VAN'S AIRCRAFT

14401 Keil Road NE, Aurora, Oregon, USA 97002

PHONE 503-678-6545 • FAX 503-678-6560 • www.vansaircraft.com • info@vansaircraft.com

Service Letters and Bulletins: www.vansaircraft.com/public/service.htm

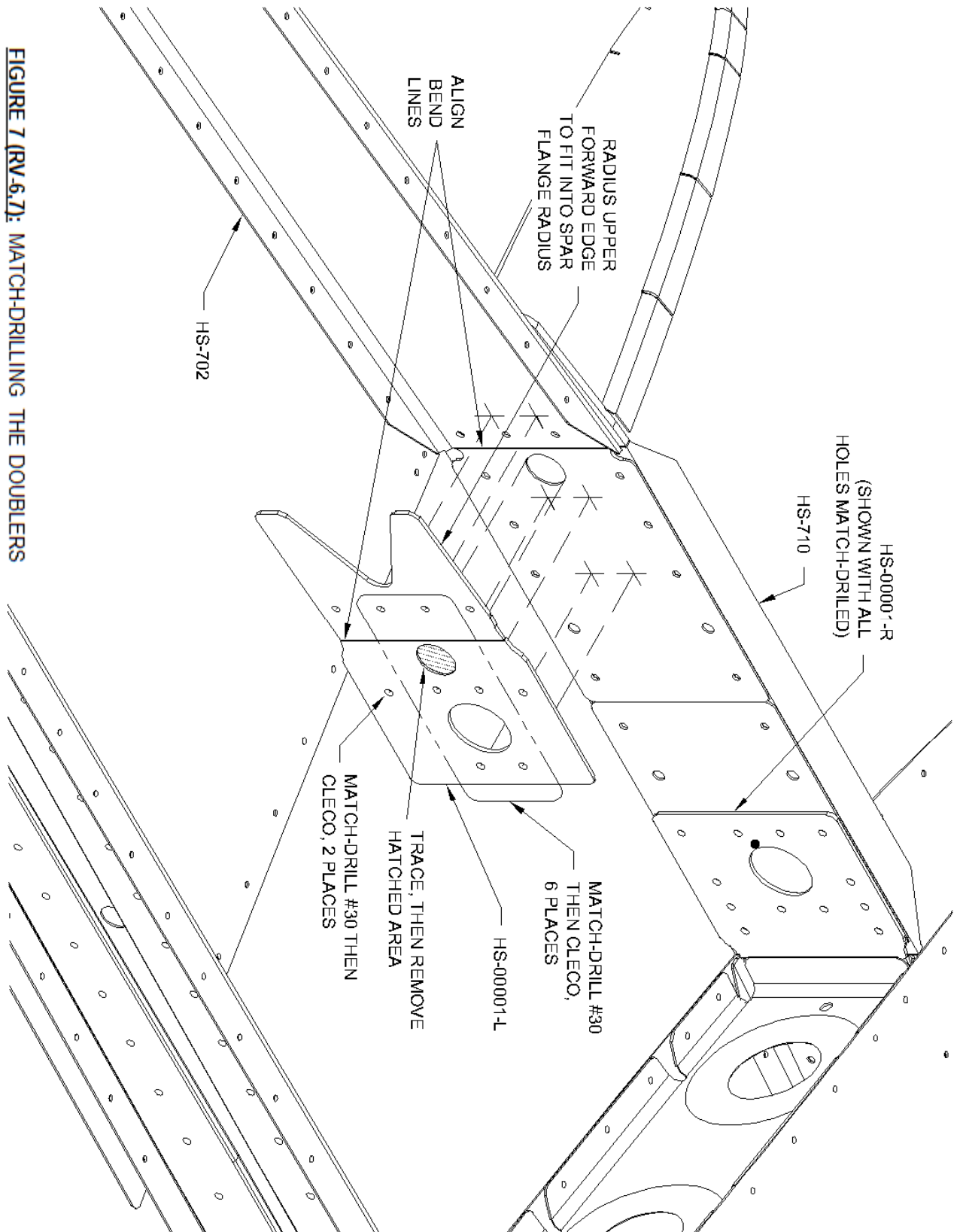

FIGURE 7 (RV-6,Z): MATCH-DRILLING THE DOUBLERS

TOTAL PERFORMANCE VAN'S AIRCRAFT

14401 Keil Road NE, Aurora, Oregon, USA 97002

PHONE 503-678-6545 • FAX 503-678-6560 • www.vansaircraft.com • info@vansaircraft.com

Service Letters and Bulletins: www.vansaircraft.com/public/service.htm

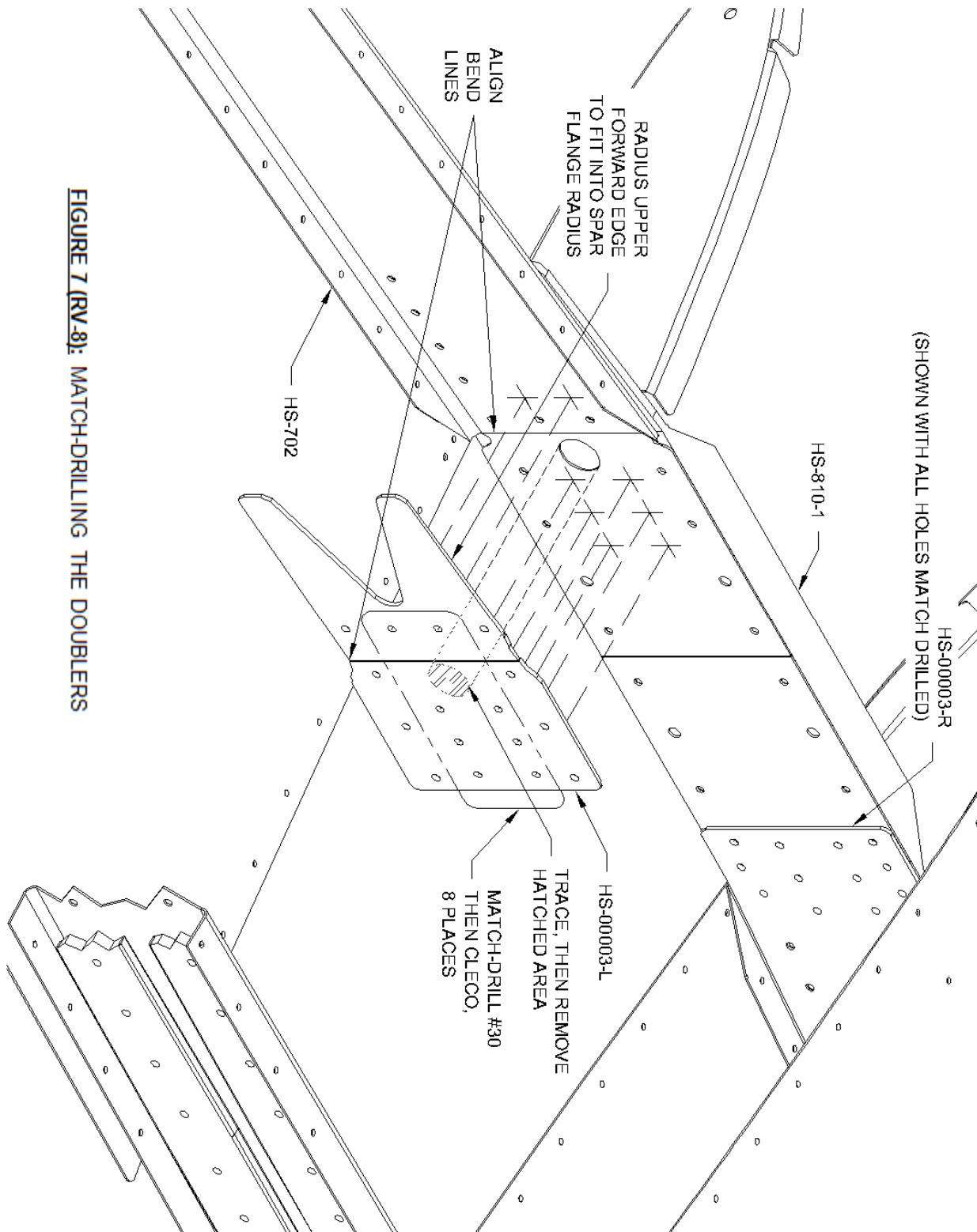

FIGURE 7 (RV-8): MATCH-DRILLING THE DOUBLERS

TOTAL PERFORMANCE
VAN'S AIRCRAFT

14401 Keil Road NE, Aurora, Oregon, USA 97002

PHONE 503-678-6545 • FAX 503-678-6560 • www.vansaircraft.com • info@vansaircraft.com

Service Letters and Bulletins: www.vansaircraft.com/public/service.htm

NOTE: Use a cleco in the hole adjacent to the hole being match-drilled as a reference for aligning the drill bit. Use a 1.5inch long bit in an angle drill to aid in making the hole perpendicular.

Step 18 (Manual Trim Only): Trace the shape of the manual trim hole from the spar onto the HS-00003-L Doubler. Un-Cleco the doubler & remove the material for the manual trim hole.

Step 19: Cleco the HS-710 Reinforcement Angle and HS-714 Splice Angle to the Horizontal Stab Assembly using the common holes in the left and right fwd spars.

Match-Drill #30 then cleco the remaining holes in the front spar and angles that were previously filled with rivets, into the doublers.

Match-Drill #30 the remaining holes in the doubler into the front spar and angles.

Step 20: Remove the doublers and angles from the assembly.

Deburr the holes drilled in the previous step. Prime the doublers if desired.

Cleco the doublers and angles to the spar.

Step 21: Cover the four rivet locations that attach the HS-405 Main Ribs to the spar with tape.

Rivet all remaining rivet locations with rivet symbols as shown in Figure 8. Install rivets with the manufactured head against the thinner material.

TOTAL PERFORMANCE VAN'S AIRCRAFT

14401 Keil Road NE, Aurora, Oregon, USA 97002
 PHONE 503-678-6545 • FAX 503-678-6560 • www.vansaircraft.com • info@vansaircraft.com
 Service Letters and Bulletins: www.vansaircraft.com/public/service.htm

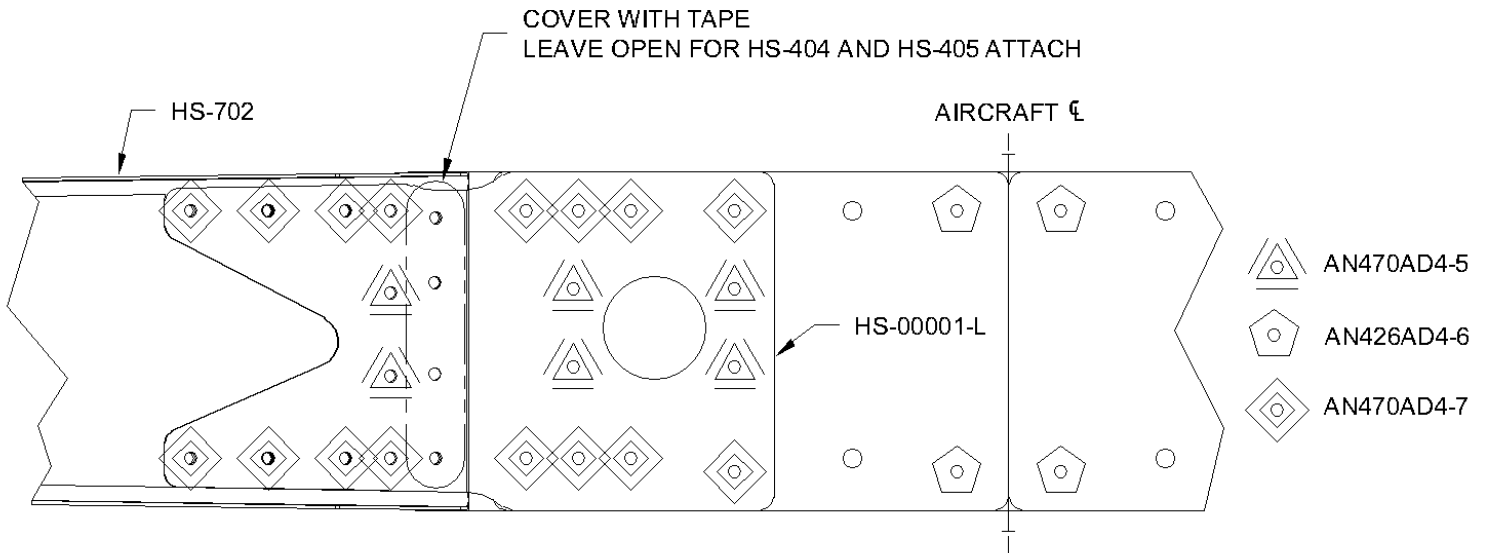

FIGURE 8 (RV-6,7): RIVETING THE DOUBLERS

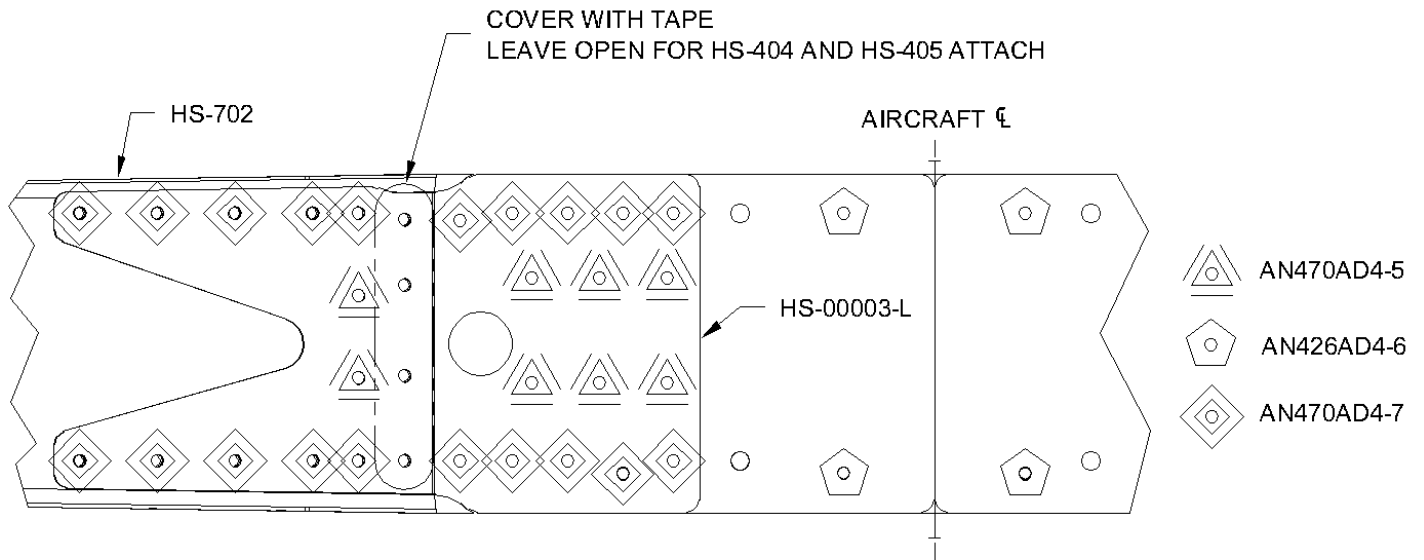

FIGURE 8 (RV-8): RIVETING THE DOUBLERS

TOTAL PERFORMANCE VAN'S AIRCRAFT

14401 Keil Road NE, Aurora, Oregon, USA 97002

PHONE 503-678-6545 • FAX 503-678-6560 • www.vansaircraft.com • info@vansaircraft.com

Service Letters and Bulletins: www.vansaircraft.com/public/service.htm

Step 22: Fabricate two HS-00002 Rib Flange Angles (RV-6,7) or HS-00004 Rib Flange Angles (RV-8) from AA3-040X3/4X1X10.5 per the dimensions given in Figure 9.

NOTE: Wherever possible, install rivets with the manufactured head on the thinner material.

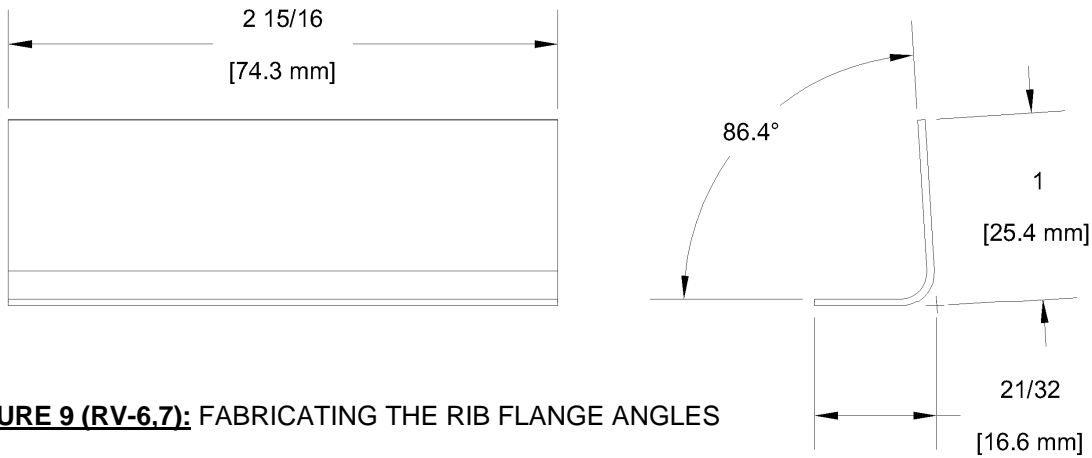

FIGURE 9 (RV-6,7): FABRICATING THE RIB FLANGE ANGLES

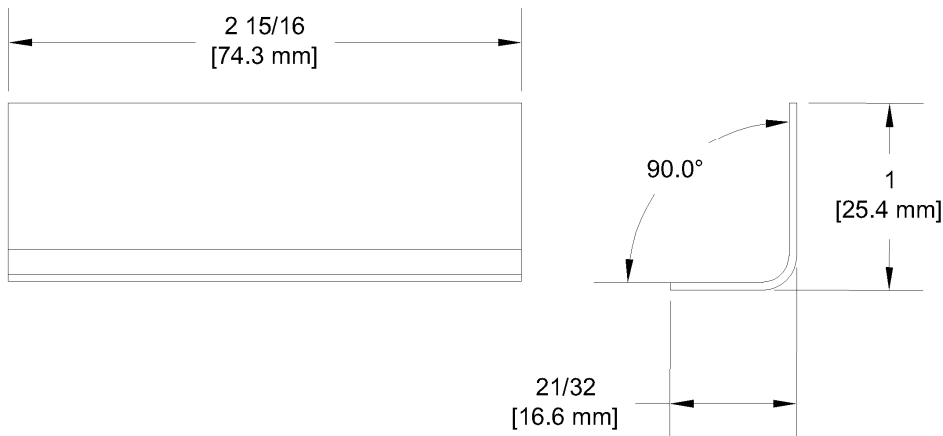

FIGURE 9 (RV-8): FABRICATING THE RIB FLANGE ANGLES

TOTAL PERFORMANCE
VAN'S AIRCRAFT

14401 Keil Road NE, Aurora, Oregon, USA 97002

PHONE 503-678-6545 • FAX 503-678-6560 • www.vansaircraft.com • info@vansaircraft.com

Service Letters and Bulletins: www.vansaircraft.com/public/service.htm

Step 23: Clamp the longer flange of a HS-00002 Rib Flange Angle to the front edge of the HS-405 Main Rib through the forward lightening hole in the rib using 2 1" C-clamps, with the clamps positioned to allow drilling access to the 4 pilot holes in the rib. Center the angle vertically about the pilot holes in the rib that were added in Step 12. See Figure 10.

Cleco the rib and flange angle assembly to the skins and rear spar of the horizontal stabilizer. Temporarily loosen the clamps and position the angle to fit tightly against the back face of the fwd spar. If the flange of the angle does not lay flush against the doubler, remove the angle and adjust the bend as needed before continuing.

Step 24: Use a wood block and clamps to secure the flange of the HS-00002 Rib Flange Angle firmly against the doubler.

Match-drill #30 then cleco the four holes that attach the forward flange of the Rib Flange Angle to the doubler and spar.

Step 25: Confirm that the clamps are **tight**. Uncleco and carefully remove the main rib and rib flange angle assy. from the stabilizer.

Step 26: Match-Drill #30 then cleco the four #40 pilot holes previously placed in the web of the main rib into the 1 inch flange of the rib flange angle. Label the angle left or right as appropriate then remove the clamps.

Step 27: Trim the 1 inch flange of the rib flange angle for 5/16 edge distance from the aft edge to the center of the holes in the flange. See the detail view in Figure 8. Radius the corners and Deburr the holes and edges of the main rib and rib flange angles.

Repeat Steps 21 through this step for the other side of the aircraft.

Step 28: Prime the HS-00001-L & -R Spar Doublers and HS-00002-L & -R Rib Flange Angles if desired.

Step 29: Rivet the rib flange angles to the HS-405-L and -R Main ribs as called out in Figure 10.

TOTAL PERFORMANCE VAN'S AIRCRAFT

14401 Keil Road NE, Aurora, Oregon, USA 97002

PHONE 503-678-6545 • FAX 503-678-6560 • www.vansaircraft.com • info@vansaircraft.com

Service Letters and Bulletins: www.vansaircraft.com/public/service.htm

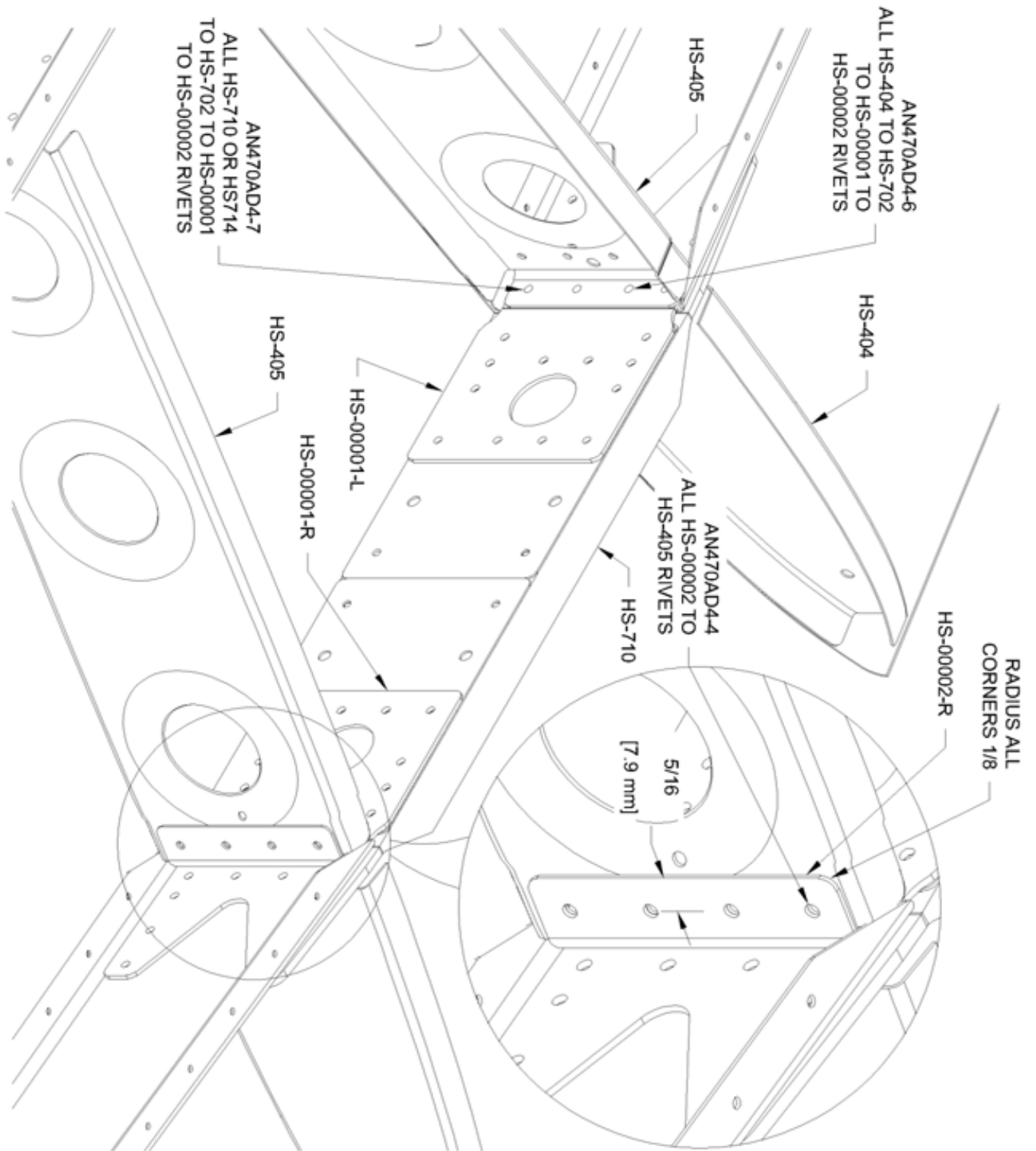

FIGURE 10: RIVETING THE RIBS TO THE SPAR

TOTAL PERFORMANCE
VAN'S AIRCRAFT

14401 Keil Road NE, Aurora, Oregon, USA 97002

PHONE 503-678-6545 • FAX 503-678-6560 • www.vansaircraft.com • info@vansaircraft.com

Service Letters and Bulletins: www.vansaircraft.com/public/service.htm

Step 30: Rivet the most inboard hole common to the skin and spar (most inboard after the spar flange was trimmed) on the top and bottom of the L & R skins. See Figure 11.

Step 31: Cleco then rivet HS-404 Nose Ribs and HS-405 Main Ribs to the front spar of the Horizontal Stab. Assembly. See Figure 10.

Step 32: Rivet the HS-405 Main Ribs to the rear spar of the Horizontal Stab. Assembly. See Figure 11.

Step 33: Cleco then rivet the ribs and nutplates to the skins. Fill the holes that formerly attached the skin to the region of the front spar flanges (removed in Step 6) with a rivet. as shown in Figure 11.

Step 34: Reinstall the empennage disassembled in Step 1.

Step 35: Make a logbook entry indicating compliance with this service bulletin.

Per AC43.13-1B, Chapter 10-2 section C no update to weight & balance is required.

TOTAL PERFORMANCE VAN'S AIRCRAFT

14401 Keil Road NE, Aurora, Oregon, USA 97002

PHONE 503-678-6545 • FAX 503-678-6560 • www.vansaircraft.com • info@vansaircraft.com

Service Letters and Bulletins: www.vansaircraft.com/public/service.htm

FIGURE 11: RIVETING THE RIBS TO THE SKINS

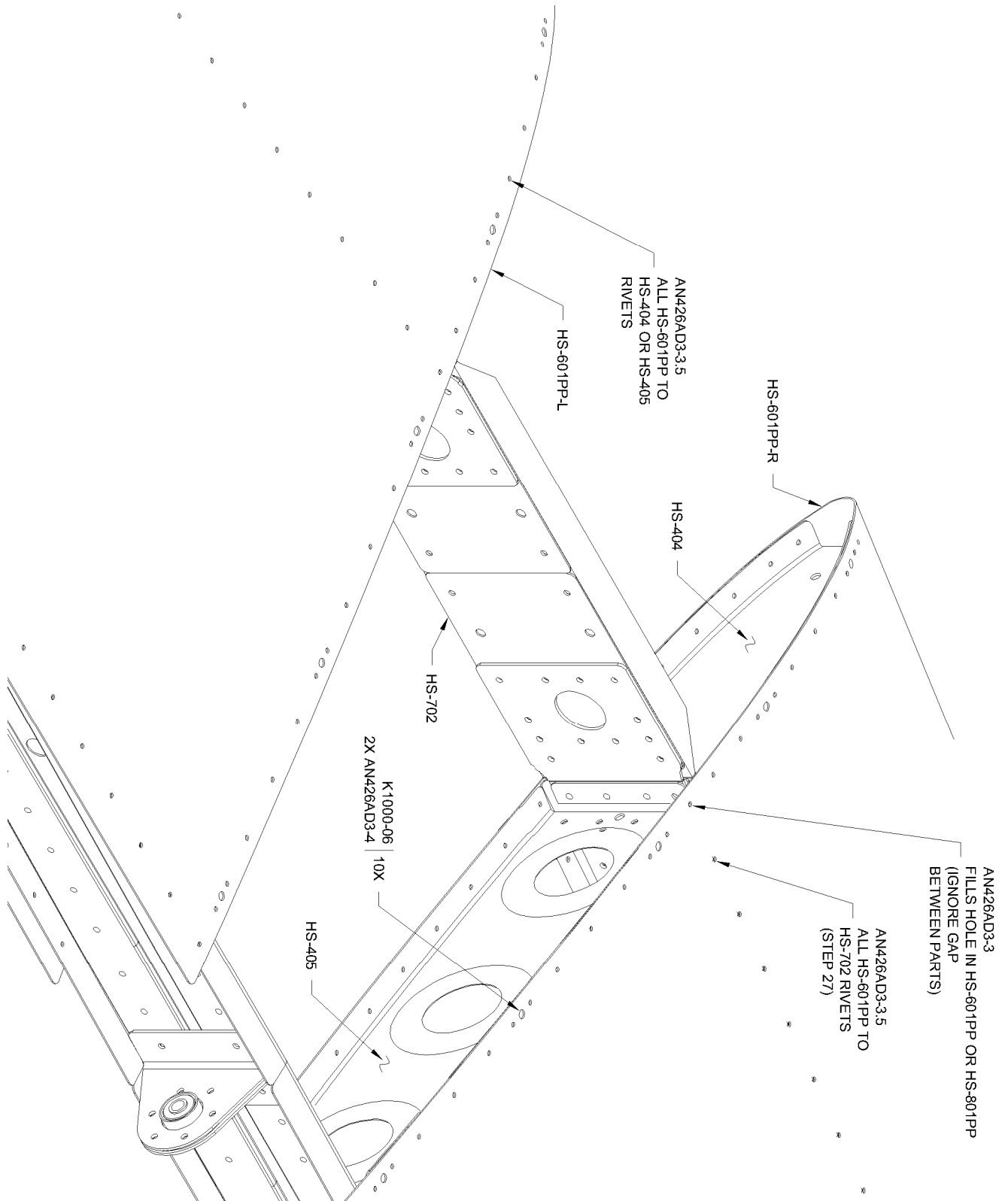

TOTAL PERFORMANCE
VAN'S AIRCRAFT

14401 Keil Road NE, Aurora, Oregon, USA 97002

PHONE 503-678-6545 • FAX 503-678-6560 • www.vansaircraft.com • info@vansaircraft.com

Service Letters and Bulletins: www.vansaircraft.com/public/service.htm

Note: Parts can be ordered from Van's Aircraft:

For RV-6/6A and RV-7/7A order **SB 14-01-31.6/7**

For RV-8/8A order **SB 14-01-31.8**

PART NUMBER

RV6,7

Qty

1	HS-00001 (RV-6,7)
1	AA3-040X3/4X1X10.5
1	2X3 .0179 304 STAINLESS SCRAP
4	AN426AD3-3
62	AN426AD3-3.5
20	AN426AD3-4
4	AN426AD4-6
8	AN470AD4-4
12	AN470AD4-5
8	AN470AD4-6
36	AN470AD4-7
10	K1000-06

RV-8

1	HS-00003 (RV-8)
1	AA3-040X3/4X1X10.5
1	2X3 .0179 304 STAINLESS SCRAP
4	AN426AD3-3
62	AN426AD3-3.5
20	AN426AD3-4
4	AN426AD4-6
8	AN470AD4-4
16	AN470AD4-5
8	AN470AD4-6
44	AN470AD4-7
10	K1000-06